

Platinum Resistance Temperature Detector

M 620

M series PRTDs are designed for large volume applications where long term stability, interchangeability and accuracy over a large temperature range are vital. Due to the high resistance values of 1000 Ω and 2000 Ω the signal gain is excellent. Typical applications are found in Automotive, White goods, HVAC, Medical and Industrial equipment.

Nominal Resistance R0	Tolerance DIN EN 60751 1996-07	Tolerance DIN EN 60751 2009-05	Order Number Plastic Bag
1000 Ohm at 0°C	Class B	F 0.3	32 208 181
2000 Ohm at 0°C	Class B	F 0.3	32 208 541

The measuring point for the nominal resistance is defined at 8mm from the end of the sensor body.

Spezification	DIN EN 60751 (according to IEC 751)	
Temperature range	-70°C to +500°C (continuous operation) (temporary use to 550°C possible) Tolerance Class B: -70°C to +500°C	
Temperature coefficient	TCR = 3850 ppm/K	
Leads	Pt clad Ni- wire Recommend connection technology: Welding, Crimping and Brazing	
Lead lengths (L)	10mm \pm 1mm	
Longterm stability	max. R ₀ -drift 0.04% after 1000h at 500 °C	
Vibration resistance	at least 40g acceleration at 10 to 2000 Hz, depends on installation	
Shock resistance	at least 100g acceleration with 8ms half sine wave , depends on installation	
Environmental conditions	unhoused for dry environments only	
Insulation resistance	> 100 M Ω at 20°C; > 2 M Ω at 500°C	
Self heating	0.3 K/mW at 0°C	
Response time	water current (v= 0.4m/s):	t _{0.5} = 0.08s t _{0.9} = 0.25s
	air stream (v= 2m/s):	t _{0.5} = 3.7s t _{0.9} = 11.5s
Measuring current	1000 Ω : 0.1 to 0,3mA 2000 Ω : 0.1 to 0,3mA (self heating has to be considered)	
Note	Other tolerances, values of resistance and wire lengths are available on request.	

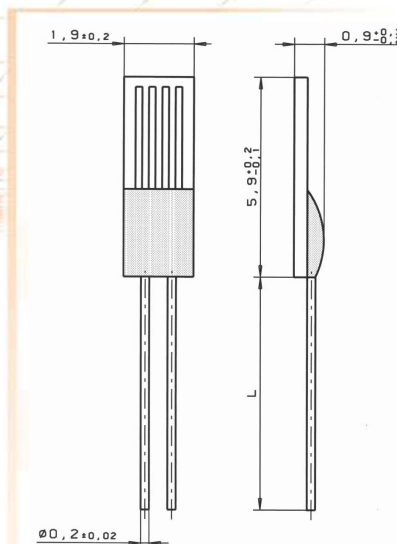

We reserve the right to make alterations and technical data printed. All technical data serves as a guideline and does not guarantee particular properties to any products.

Heraeus Sensor Technology GmbH, Reinhard- Heraeus- Ring 23, 63801 Kleinostheim, Germany
Phone: +49 (0) 6181/35-8098, Fax: +49 (0)6181/35-8101, E-Mail: info.HSND@Heraeus.com Web: www.heraeus-sensor-technology.com